



SLIDE-OUT CONTROL REPLACEMENT

© Copyright PowerGear Issued: May 2011

#82-S0510, Rev. 0A May 2011

WARNING

DO NOT WORK ON OR AROUND A VEHICLE THAT CAN BE MOVED. To ensure personal safety, place the transmission into PARK (NEUTRAL) and set the parking brake. Turn off the ignition and remove the ignition key. Maintain control of keys while working. Attach a notice, "DO NOT USE", to the ignition switch in order to prevent activation of the systems.

Replacement of 140-1249 control with a 140-1249S or 1510000165 control

Introduction

Slide-out control number 140-1249 is now obsolete. Part orders for a 140-1249 will have current control number 140-1249S or 1510000165 shipped as a direct replacement.

This tip sheet will guide you through replacement and programming of the 140-1249S or 1510000165.

The 140-1249S and the 1510000165 are functionally the same control except for the following visual differences:

- The 1510000165 control has "flying" electrical connection leads (see **FIGURE 2**) while the 140-1249S has electrical connectors on the control board (see **FIGURE 1**).
- 140-1249S has visible red colored FIELD RESET buttons that could be pressed with your finger tips (see **FIGURE 1**). On the 1510000165 the FIELD RESET buttons are now labeled O and I. They are recessed into the control and they must be pressed with something small such as the end of a paper clip.

To complete the steps outlined in this procedure, you will need the following:

- Programmer/Teach Pendant (see **FIGURE 3**), part number 140-1176 (available for purchase through Power Gear).
- This Tip Sheet, #82-S0510

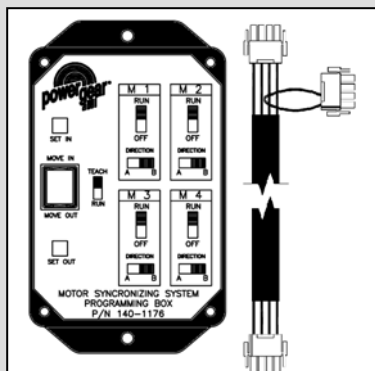

Figure 3

Part # 140-1176

Programmer/Teach Pendant

Installation

Installation of new control:

1. Mark all existing harness connections at the slide control mounting location.
2. Unplug all harness connections from the existing control.
3. Install the replacement control in the same location.
4. Connect the main power and ground wires to the control box terminals. **BE SURE TO CONNECT THE GROUND WIRE FIRST.**
5. Reconnect all of the previously marked harnesses into the new control. Verify all harnesses are connected into the proper location on the control.
6. You are now ready to program the control using the teach pendant (FIGURE 3).

Red Field Reset Buttons

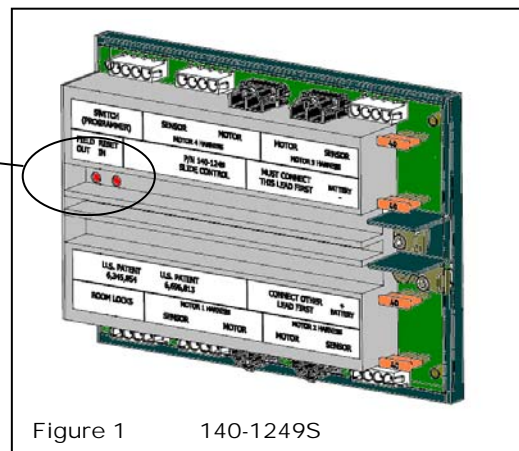

Figure 1

140-1249S

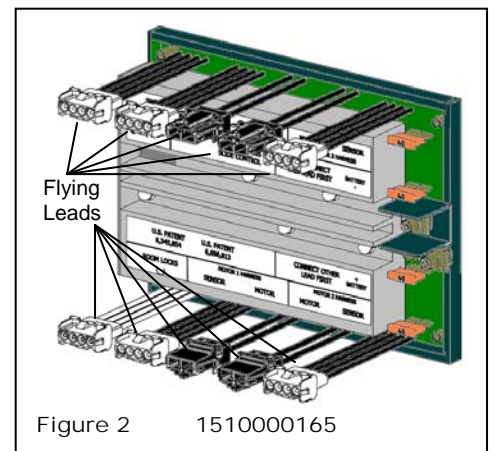

Figure 2

1510000165



WARNING

Follow these instructions exactly. Failure to do so may result in unsuccessful programming of the new control, coach damage or personal injury.

DO NOT WORK ON OR AROUND A VEHICLE THAT CAN BE MOVED. To ensure personal safety, place the transmission into PARK (NEUTRAL) and set the parking brake. Turn off the ignition and remove the ignition key. Maintain control of keys while working. Attach a notice, "DO NOT USE", to the ignition switch in order to prevent activation of the systems.

NOTE

New controls are shipped WITHOUT the stops programmed. If the stops have already been programmed, pressing the O and I buttons (see figure 7, page 3) will clear the stops, and the control will have to be reprogrammed before it will function. Only press the O and I buttons when directed to do so during control programming.

Programming the new control

1. Make sure all obstructions are out of the path of the slide-out and room locks are in the stowed position or retracted position which is flat against the slide-out wall.
2. Run the coach engine and verify the incoming voltage to the slide-out control box between the **BATTERY (-)** and **BATTERY (+)** at control box terminals (see **FIGURE 4, page 3**). The incoming power needs to be +13.1V DC or more.
3. Connect the programmer/teach pendant as follows:
 - a. Insert the programmer end of the harness into the **PROGRAMMER/TEACH PENDANT** (see **FIGURE 5, page 3**).
 - b. Insert the controller end of the harness into the connector labeled **SWITCH (PROGRAMMER)** on the slide-out control board (see **FIGURE 4, page 3**).
 - c. Insert the room lock connector of the programmer/teach pendant harness into the connector labeled **ROOM LOCKS** on the slide-out control board (see **FIGURE 4, page 3**).
4. Move the **Teach /Run** switch to **Run**.
5. To enter programming mode, remove the foil sticker covering the O and I buttons on the new control (see **FIGURE 6, page 3**). Using a paper clip (or similar item) simultaneously press the O and I buttons located on the slide out controller for 5 seconds (see **FIGURE 7, page 3**). Press firmly. It is not necessary to replace the foil sticker.
6. Move the **Teach /Run** switch of the **PROGRAMMER/TEACH PENDANT** to **Teach**.
7. Testing each motor direction: check one motor at a time to verify that each motor moves in when **MOVE IN** is pressed and out when **MOVE OUT** is pressed.
 - a. Switch **M 1** to **Run** and all the others to **Off**. Momentarily press the **MOVE IN** button to see if the **M1** motor moves the slide out in. If not switch the direction with the **A-B** direction switch under **M1**.
 - b. Switch **M 2** to **Run** and all the others to **Off**. Momentarily press the **MOVE IN** button to see if the **M2** motor moves the slide out in. If not switch the direction with the **A-B** direction switch under **M2**.
 - c. Switch **M 3** to **Run** and all the others to **Off**. Momentarily press the **MOVE IN** button to see if the **M3** motor moves the slide out in. If not switch the direction with the **A-B** direction switch under **M3**.
 - d. Switch **M 4** to **Run** and all the others to **Off**. Momentarily press the **MOVE IN** button to see if the **M4** motor moves the slide out in. If not switch the direction with the **A-B** direction switch under **M4**.
8. After confirming the direction is correct for all the motors, switch them all to **Run**. Run all the motors **IN** until they are in the fully retracted position, turning off individual motors as necessary to achieve a good seal. The controller will not accept a stop point from a stalled motor, so the seal should be approximately 50% crushed. Press the **SET IN** button to store the **IN** position.
9. Run all the motors **OUT** until they are in a fully extended position, turning off individual motors as necessary to achieve a good seal. The controller will not accept a stop point from a stalled motor, so the seal should be approximately 50% crushed. Press the **SET OUT** button to store the out position. The **PROGRAMMER/TEACH PENDANT** should no longer operate in the teach mode at this point. Test this by pressing **IN** or **OUT**. **If the room moves**, the control was not programmed correctly. Return to STEP 4 to restart the programming procedure. **If the room does not move, programming is complete**, proceed to step 10.
10. Move the **Teach/Run** switch to the **Run** position. Cycle the room **IN** and **OUT** to verify that the control held the stop points.
11. If you need to re-teach the stop points, repeat step 4-10.
12. Remove plugs from the control marked **SWITCH (PROGRAMMER)** and **ROOM LOCKS** and reinstall the coach wiring harnesses into the slide out control connectors.

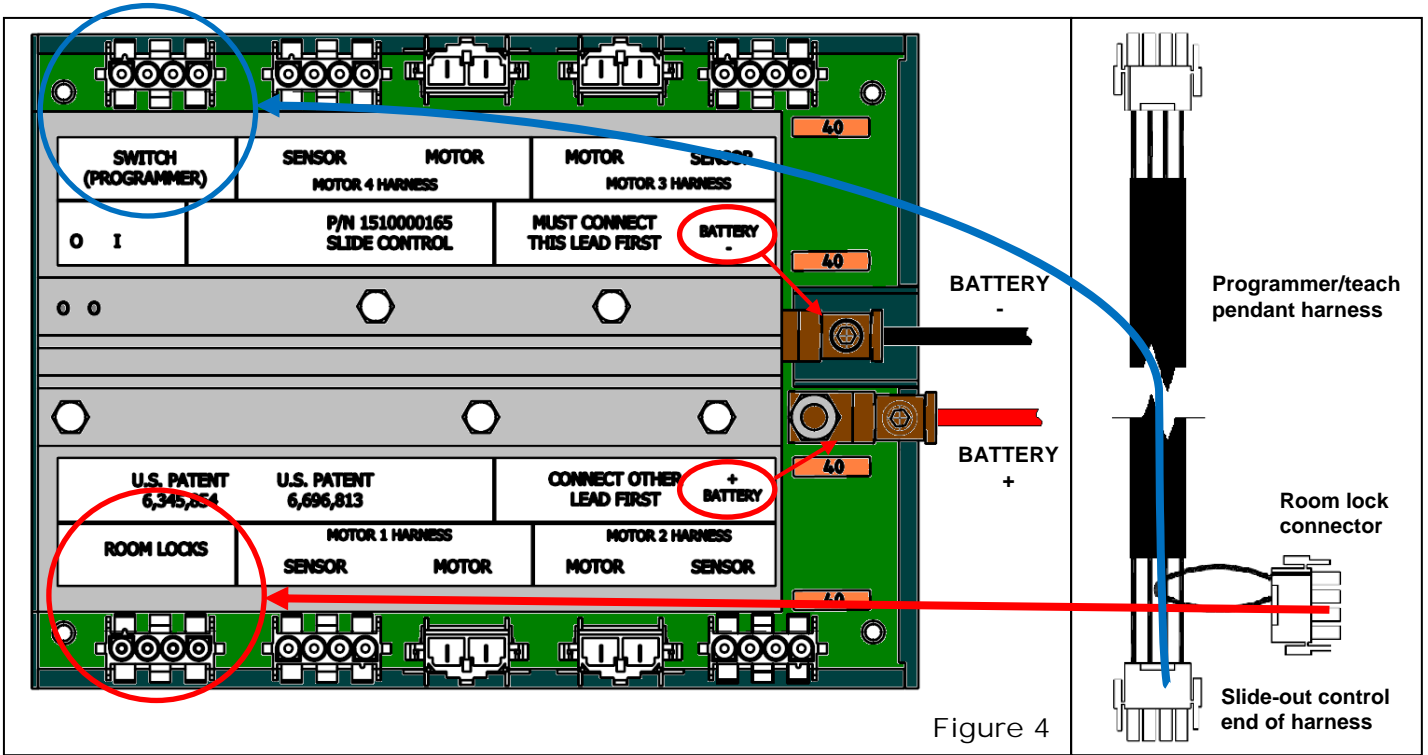

Figure 4

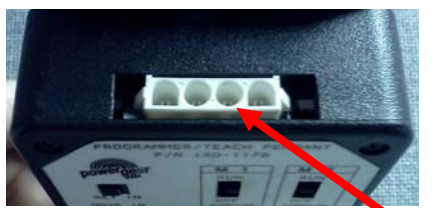

Figure 6 Foil sticker

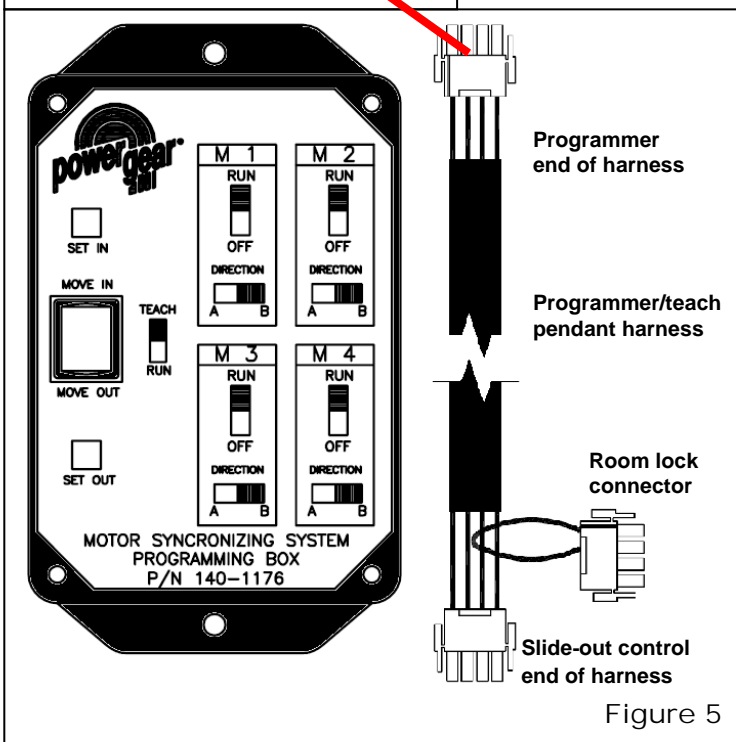

Figure 5



Figure 7 Pressing the O and I buttons