



SLIDE-OUT CONTROL REPLACEMENT

© Copyright PowerGear Issued: June, 2011

#82-S0512, Rev: Release June, 2011

WARNING

DO NOT WORK ON OR AROUND A VEHICLE THAT CAN BE MOVED. To ensure personal safety, place the transmission into PARK (NEUTRAL) and set the parking brake. Turn off the ignition and remove the ignition key. Maintain control of keys while working. Attach a notice, "DO NOT USE", to the ignition switch in order to prevent activation of the systems.

Replacement of waterproof relay pack DN13003 with non waterproof relay pack DN13819

General Information

- Waterproof relay pack # DN13003 (**FIGURE 1**) is no longer available. It is currently being replaced with **NON-WATERPROOF** relay pack # DN13819 (**FIGURE 2**).
- Functionally, the replacement relay pack is the same as the original. The only difference is that the new one is **NOT WATERPROOF**.
- The new relay pack # DN13819 must be located in an area that is free from moisture. Failure to properly locate or sufficiently protect it from moisture will result in a forfeiture of warranty coverage. Any relay pack returned for warranty consideration showing evidence of being exposed to moisture will not be covered.
- If the relay pack is moved to a location free from moisture, then it must be wired and fused per the latest edition of ANSI/RVIA standard for low voltage systems in conversion and recreational vehicles.

Replacement

1. Remove wires individually from old relay pack and replace in the same location on the new relay pack (M1 to M1, Red to Red, etc.).
2. Remove old relay pack.
3. Install the new relay pack and secure it to a moisture free mounting location.
4. Replacement is complete.

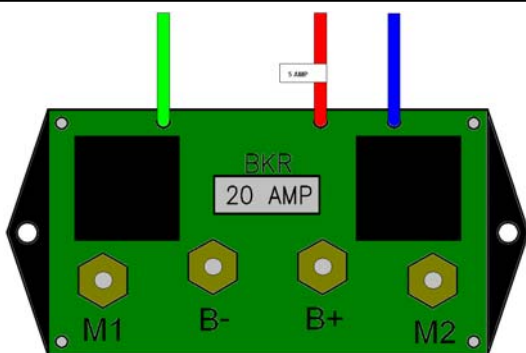

Figure 1 DN13003

Note: M1, B-, B+, and M2 labels may be on the side of older versions of this control.

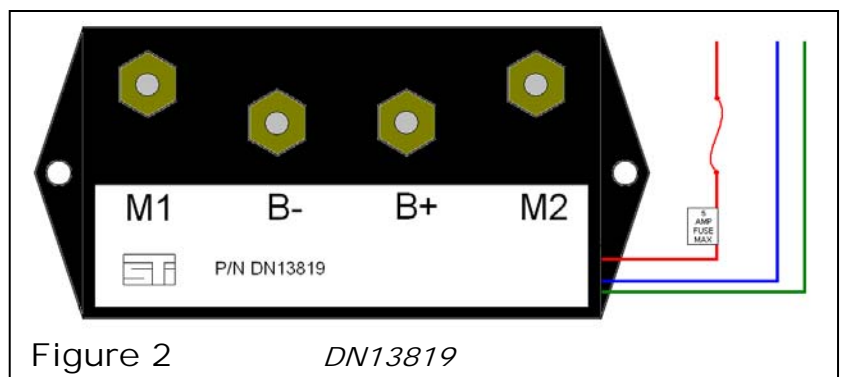

Figure 2 DN13819

